

DURBAL

THE PERFECT ROD END



DURBAL





DURBAL heavy-duty rod ends are standardized ready-to-be-installed machine components serving the transmission of static and dynamic forces in combination with swiveling, tilting or rotating movement. Bearing the Name »Schlegel«, the rod ends with integrated self-aligning ball bearing were initially used in the aircraft industry. In the meantime, our heavy-duty rod ends have become a standard concept in all industrial applications, under the name »DURBAL«.

The DURBAL heavy duty rod ends are distinguished by their high precision and reliability. The quality of DURBAL products is systematically planned, manufactured and controlled by the QM-System, which was certified official-

ly in March 1996 and is in accordance with DIN ISO 9001 which is valid for all areas of enterprise.

The universal product range is available ex stock and consists of DURBAL heavy-duty rod ends with maintenance-free plain bearings or low-maintenance antifriction bearings, offering an optimal choice for a wide range of different applications.

The selection criteria and calculation basics contained in this catalogue are based on numerous endurance test runs and more than 50 years of experience. This enables an individual adoption of the features of our DURBAL heavy-duty rod ends to the requirements of the individual application.

DURBAL heavy-duty rod ends are available with connections in metric dimensions according to DIN 648, CETOP RP 103 P, or in INCHES.

This catalogue represents the latest state of our technical and manufacturing developments and therefore earlier catalogues are not longer valid. The given specifications are subject to change due to technical improvements.

Our experienced staff is always at your service to answer any query you may have.



Fachauschüsse Eisen und Metall III
und Hebezeuge II
Prüf- und Zertifizierungsstelle
im BG-PRÜFZERT

Hauptverband der gewerblichen
Berufsgenossenschaften

Zertifikat

Nr.

96161

gültig bis

30.06.2001

Das **Qualitätsmanagementsystem** der

Firma DURBAL GmbH & Co.
Verrenberger Weg 2-2A, 74604 Öhringen

für **das Gesamtunternehmen**

entspricht der **DIN EN ISO 9001 : 1994.**

Düsseldorf, den 22.03.1996

Unterschrift 
(Dipl. Ing. Bührmann)

ZQ801
03/95



Postadresse:
Postfach 10 10 15
40001 Düsseldorf

Hausadresse:
Graf-Recke-Str. 69
40239 Düsseldorf ZQS01

Telefon:
02 11/6 70 08-0

Telefax:
02 11/6 70 08-44

DURBAL Inc.
14115 - 63rd Way North
Clearwater Florida
33760 USA











Phone 727-539-7824

Fax 727-539-7824

www.durbal.com
email; durbal@durbal.com



Table of contents

Technical introduction				Page
	Selection • Definitions • Calculation • Tolerances			4-10
DURBAL	heavy-duty rod ends with integral self-aligning ball bearing adapter sizes according to DIN 648, series K		BRM BRF	11-12
DURBAL	heavy-duty rod ends with integral self-aligning ball bearing		PM PF	13-14
DURBAL	heavy-duty rod ends with integral self-aligning roller bearing adapter sizes according to DIN 648, series K		BRTM BRTF	15-16
DURBAL	heavy-duty rod ends with integral spherical plain bearing adapter sizes according to DIN 648, series K; maintenance-free thread according to Cetrop RP 03 P		BEM BEF	17-18
DURBAL	heavy-duty rod ends with integral spherical plain bearing adapter sizes according to DIN 648, series E; maintenance-free		EM EF	19-20
DURBAL	heavy-duty rod ends with integral self-aligning ball bearing dimensions in inches		BRM BRF	21-22
DURBAL	heavy-duty rod ends with integral self-aligning roller bearing dimensions in inches		BRTM BRTF	23-24
DURBAL	heavy-duty rod ends with integral spherical plain bearing dimensions in inches; maintenance-free		BEM BEF	25-26
DURBAL	heavy-duty rod ends with integral spherical plain bearing adapter sizes according to DIN 648, series K NIRO stainless steel		BEM BEF	27-28
DURBAL	DURBAL DIRT SHIELD - extends operating life in contaminated areas A neoprene cup bonded to a stainless steel washer shields the bearing		DDS	29



DURBAL heavy-duty rod ends are sturdy, robust, precision bearings that are maintenance-free or with greasable rolling elements. The selection tables in this catalog incorporate a broad choice of rod ends to meet your specific requirements.

DURBAL heavy-duty rod ends with integral self-aligning ball bearings, Series BRM, BRF, PM, PF

This design is especially suitable for high speeds, large swiveling angles or rotating movements with relatively low or medium loads. Prominent technical features are the low bearing friction, sealing

against rough dirt penetration by means of shields on both sides. Under normal operating conditions the rod ends are maintenance-free. A Grease nipple is provided for lubrication during rough service and maximum loads.

To avoid incompatibility with the initial lubrication, we recommend lubricating with a calcium-complex-soap-grease or Polyrex EP2.

A special heat treatment procedure matches the rod end housing raceway hardness to the antifriction bearings, ensuring the same time high stability with changing loads.

DURBAL heavy-duty rod ends with integral self-aligning roller bearings, Series BRTM, BRTF

The design based on the structure of a self-aligning roller bearing is preferably used for high speed, large tilting angles or rotating motion with medium loads. Compared to rod ends with self-aligning ball bearings, rod ends with self-aligning roller bearings have essentially higher basic load ratings. This design is equipped with a cage to minimize the rolling friction and heat built-up. These rod ends are

under normal operating conditions maintenance-free. A Grease nipple is provided for lubrication in case of rough operation and maximum load.

To avoid incompatibility with the initial lubrication, we recommend lubricating with a calcium-complex-soap-grease or Polyrex EP2. Shields on both sides prevent dirt particles from penetrating into the bearing. The rod ends with self-aligning roller bearings are, just as the design with self-aligning ball bearings, subjected to a special heat treatment procedure to match the raceway hardness to the antifriction bearings, ensuring at the same time a high stability with changing loads and temperature.

DURBAL heavy-duty rod ends with a integral maintenance-free spherical plain bearing, Series BEM, BEF, EM, EF

In many cases DURBAL heavy-duty rod ends with integrated spherical plain bearing serve their purpose. They are primarily used for small swiveling or tilting movements at low speeds. They stand out for their high loadability and can also be used for shock loads. The ball slides on a composite bearing shell consisting of a glass fiber-filled nylon/teflon component. This design ensures an absolutely maintenance-free rod end. DURBAL heavy-duty plain bearing rod ends have a slight initial stress and virtually no clearance. The composite material used has a favorable secondary advantage in that it absorbs any foreign particles and embeds them so that no damage can occur. The joint balls of DURBAL heavy-duty rod ends with integrated spherical plain bearings are hard chrome plated.

This reliable corrosion protection ensures that the function of the rod end will not be affected by a corroded ball surface under humid operating conditions.

Basic load ratings

Static basic load rating of antifriction bearing rod ends

The static basic load rating C_0 of an antifriction bearing rod end corresponds to that of a static radial load causing a lasting overall deformation of 1/10.000 of the roller body diameter at the contact point.

Static basic load ratings of plain bearing rod ends

The static basic load rating C_0 of a plain bearing rod end corresponds to that of the static radial load that does not yet cause a lasting deformation at the weakest housing section. It contains at least a 1.2 safety factor compared to the yield stress of the material used for the rod end housing.

Dynamic basic load rating of antifriction bearing rod ends

The dynamic basic load rating C of an antifriction bearing rod end is the external radial load, unchangeable in size and direction, at which 90 % of a statistical sample of identical rod ends will reach or exceed 1 million of rotations or swiveling movements.

Dynamic basic load ratings of plain bearing rod ends

The dynamic basic load rating C is the parameter for the calculation of dynamically loaded maintenance-free DURBAL heavy-duty rod ends with integrated spherical plain bearing, in other words, making tilting, swiveling or rotating movements under load.

Basic load ratings always depend on the definitions they are based on. For this reason it is not always possible to compare basic load rating data supplied by different manufactures.

Operating temperatures

DURBAL heavy-duty antifriction bearing rod ends can be used for operating temperatures between -20 °C and $+120\text{ °C}$.

The temperature range of DURBAL heavy-duty rod ends with integral spherical plain bearing is between -30 °C and $+60\text{ °C}$, without affecting the loadability. Higher temperatures will reduce the loadability taken into account for the calculation of the working life under the temperature factor C_2 .

Loads

The decisive parameters for the selection and calculation of DURBAL heavy-duty rod ends are size, direction and type of load.

Radial or combined loads

The DURBAL heavy-duty rod ends have been especially designed to adopt high radial loads.

They can furthermore be used for combined loads, the axial load share of which does not exceed 20% of the corresponding radial load.

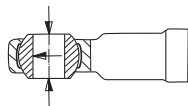

Unilaterally acting load

In this case the load acts only in the same direction, which means that the load area is always in the same bearing section.

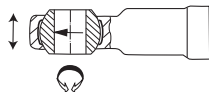

Alternately acting load

In case of alternating loads, the load areas facing each other are alternately loaded and/or relieved, which means that the load changes its direction constantly by approx. 180 ° .

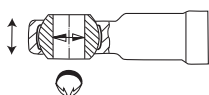

Swivelling angle

The swivelling angle is the excursion of the rod end from one final position to the other. Half the swivelling angle β is used to calculate the service or working life.

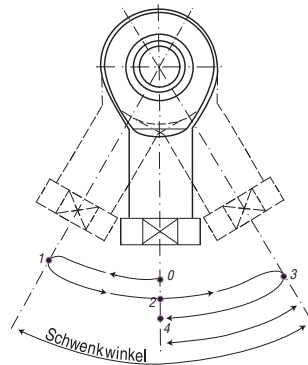

Angle of Misalignment

The angle of tilt, also called ^{misalignment} angle, refers to the possible excursion of the joint ball and/or the inner ring to the rod end axis in degrees. The tilting angle indicated in the table for the DURBAL heavy-duty antifriction bearing rod ends corresponds to the max. Possible excursion being limited by the shields on both sides. It is important that this tilting angle is not exceeded either during installation or operation, as otherwise the shields may be damaged. As far as DURBAL heavy-duty plain bearing rod ends are concerned, distinction is made between the tilting angles α_1 and α_2 .

If the excursion is not limited by adjacent components, excursion angle α_1 can fully be used without affecting the rod end capacity. Tilting angle α_2 is the excursion limit when connecting a forked component.

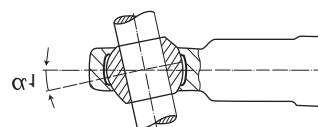
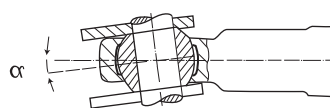

Nominal service life

The term »nominal service life« is used for DURBAL heavy-duty antifriction bearing rod ends and represents the number of swivelling motions or rotations and/or the number of service hours the rod end performs before showing the first signs of material fatigue at the raceway or roller bodies. In view of many influence factors that are difficult or impossible to assess, the service life of several obviously identical bearings differ under the same operating conditions. For this reason, the following method for the service life determination of DURBAL heavy-duty antifriction rod ends results in a nominal service life being achieved or exceeded by at least 90 % of a larger quantity of identical rod ends.

Working life

The term »working life« is used with DURBAL heavy-duty plain bearing rod ends. It represents the number of swivelling motions or rotations and/or the number of services hours the DURBAL heavy-duty plain bearing rod end performs before becoming unserviceable because of material fatigue, wear, increased bearing clearance or increase of the bearing friction moment. The working life is not only influenced by the size and the type of load, it is also affected by a number of factors, which are partially difficult to assess. A calculation of the exact servicelife is therefore impossible. Field-experienced standard values for the approximate working life can nevertheless be determined by using the following calculation procedure which is based on numerous results from endurance test runs and values from decades of experience. The values determined by this formula are achieved, if not exceeded, by the majority of the DURBAL heavy-duty rod ends.

Calculations

Antifriction bearing construction

DURBAL – heavy-duty rod ends with integral self-aligning ball bearing Series BRM, BRF, PM, PF

Normal service life

rotating
$$L_{h_{rot.}} = 10^6 \frac{\left(\frac{C}{P}\right)^3}{60 \cdot n} \quad [h] \quad (1)$$

oscillating
$$L_{h_{osz.}} = 10^6 \frac{\left(\frac{C}{P^3 \sqrt{\frac{\beta}{90}}}\right)^3}{60 \cdot f} \quad [h] \quad (2)$$

condition:
swivelling angle $\beta \geq 3^\circ$
For swiveling angles $\beta \geq 3^\circ$ we
recommend the use of DURBAL
heavy-duty plain bearing rod ends.

Static load

constant $P_0 \leq C_0 [N] \quad (3)$

DURBAL – heavy-duty rod ends with integral self-aligning roller bearing Series BRTF, BRTM

Nominal service life

rotating:
$$L_{h_{rot.}} = 10^6 \frac{\left(\frac{C}{P}\right)^{3,333}}{60 \cdot n} \quad [h] \quad (4)$$

oscillating:
$$L_{h_{osz.}} = 10^6 \frac{\left(\frac{C}{P^3 \sqrt{\frac{\beta}{90}}}\right)^{3,333}}{60 \cdot f} \quad [h] \quad (5)$$

Condition:
swivelling angle $\beta \geq 3^\circ$
For swiveling angles $\beta \geq 3^\circ$ we
recommend the use of DURBAL
heavy-duty plain bearing rod ends.

Static load

constant $P_0 \leq C_0 [N] \quad (6)$



$L_{h \text{ rot}}$ nominal service life for rotation [hours of operation]
 $L_{h \text{ osz}}$ nominal service life for oscillating movement [hours or operation]
 C basic dynamic load rating [N], see tables
 C_0 basic static rating [N], see tables

P Dynamic equivalent load [N]

Rod ends with integral self-aligning ball bearing: $P = F_r + y \cdot F_a$ (7)

Rod ends with integral self-aligning roller bearing: $P = F_r + 9,5 \cdot F_a$ (8)

P_0 Static equivalent load [N]

Rod ends with integral self-aligning ball bearing: $P_0 = F_r + y_0 \cdot F_a$ (9)

Rod ends with integral self-aligning roller bearing: $P_0 = F_r + 5 \cdot F_a$ (10)

F_a axial load [N]
 F_r radial load [N]
 F_r axial factor, dynamic, see tables
 Y axial factor, static, see tables
 Y_0 half the swiveling angle [degrees]
 β $\beta = 90^\circ$ should be used for rotation
 n rotation speed limit [min-1]
 f frequency of oscillation [min-1]

Calculation example

At the rotating side of crank mechanism, a DURBAL heavy-duty antifriction bearing rod end should be installed. The expected service life amounts to at least 5,000 hours.

Known: rotation speed $n = 300 \text{ min}^{-1}$, radial load $F_r = 750 \text{ N}$

Selected: BRF 8
 $C = 4000 \text{ N}$

$$\begin{aligned}
 L_{h \text{ rot.}} &= 10^6 \frac{\left(\frac{C}{P}\right)^3}{60 \cdot n} \\
 &= 10^6 \frac{\left(\frac{4000}{750}\right)^3}{60 \cdot 300} = \underline{\underline{8428 \text{ h} > 5000 \text{ h}}}
 \end{aligned}$$

Calculations

Plain bearing construction

Working life

$$G = C_1 \cdot C_2 \cdot C_3 \cdot \frac{3}{d_8 \cdot \beta} \cdot \frac{C}{P} \cdot 10^8 \quad (11)$$

$$G = C_1 \cdot C_2 \cdot C_3 \cdot \frac{5}{d_8 \cdot \beta} \cdot \frac{C}{P} \cdot 10^6 \quad (12)$$

G	working life [number of oscillating or revolutions]
Gh	Working life [hours of operation]
C	basic dynamic load rating [N], see tables
d _g	joint ball diameter [mm]
β	half the swiveling angle [degrees], β = 90° should be used for rotation
f	frequency of oscillation [min-1]
C ₁	load direction factor, see following table
C ₂	temperature factor, see following table
C ₃	material factor, see following table
C ₄	factor for type of load, see following table
P	Equivalent dynamic load [N]

$$P = F_r + F_a \leq P_{zul} \quad (13)$$

F _r	radial load component [N]
F _a	axial load component [N], condition: F _a ≤ 0,2 · F _r

P_{max.} maximum permissible rod end [N]

$$P_{zul} = C_0 \cdot C_2 \cdot C_4 \quad (14)$$

C₀ Basic static load rating, [N], see tables

Load direction factor c₁

Single load direction: **c₁ = 1,0**
 alternating load direction, at f < 30 min-1: **c₁ = 0,25**
 alternating load direction, at f > 30 min-1: **c₁ = 0,125**

Temperature factor c₂

temperature	c₂
≤ 60°C	1,0
60°C to 80°C	0,8
80°C to 100°C	0,7
100°C to 110°C	0,6

Material factor c₃

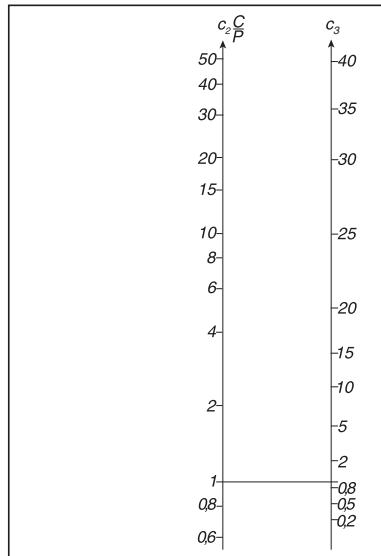

Static load

If DURBAL heavy-duty rod ends support loads while stationary or with very little movement, the maximum permissible load is not a result of wear but a function of the material strength of the race or the rod end housing. If static loads are a combination of radial and axial loads, the equivalent static bearing load will have to be calculated.

Calculation are identical with those of the equivalent dynamic bearing load – see equation (13), page 8.

Permissible sliding velocity

The permissible sliding velocity of DURBAL heavy-duty rod ends depends mainly on the load and temperature conditions. Heat generated through friction in the rod end housing itself is the main limitation on sliding velocity. When selecting the rod end size, it is necessary, to determine the sliding velocity and the pv-value, which is a product of the specific bearing load p [N/mm²] and the sliding velocity v [m/s].

The following standard values refer to swiveling and rotating movements. With improved cooling, speeds may be increased.

Permissible pv-value = 0,5 N/mm² · m/s

Permissible sliding velocity

$$V_{max.} = 0,15 \text{ m/s} \geq V_m$$

Factor for type of load C₄

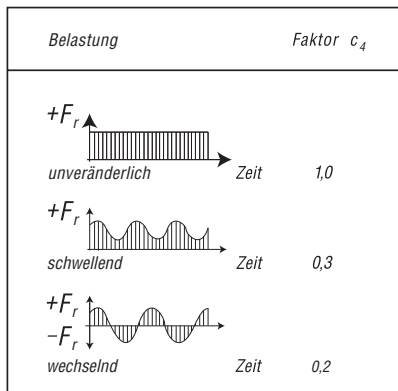



Specific bearing load

$$p = k \cdot \frac{P}{C} \quad (15)$$

- p specific bearing load [N/mm²]
 P equivalent dynamic load [N], see equation (13), page 8
 C basic dynamic load rating [N], see tables
 k specific load factor [N/mm²] for sliding contact surfaces steel on nylon/teflon/fiber glass
 $k = 50 \text{ N/mm}^2$

Mean sliding velocity

$$V_m = 5,82 \cdot 10^{-7} \cdot d_g \cdot \beta \cdot f \quad (16)$$

- V_m mean sliding velocity [m/s]
 d_g joint ball diameter [mm], see tables
 β half the swiveling angle [degrees], $\beta = 90^\circ$ should be used for rotation
 f frequency of oscillation [min⁻¹]

Calculation example

The rod assembly of a conveyor equipment calls for a DURBAL heavy-duty rod end with a working life of 8,000 hours in conjunction with an alternating acting load of 5,000 N.

25 swiveling movements with a swiveling angle of 30° take place per minute. The operating temperature amounts to approx. 60 °C.

The choice is a DURBAL heavy-duty rod end EF 15 with $C = 19415 \text{ N}$, $d_g = 22 \text{ mm}$.

Working life

$$G_h = C_1 \cdot C_2 \cdot C_3 \cdot \frac{5}{d_g \cdot \beta \cdot f} \cdot \frac{C}{P} \cdot 10^6$$

$$c_1 = 0,25 \text{ (alternating load direction, } f = 25 \text{ min}^{-1} < 30 \text{ min}^{-1}\text{)}$$

$$c_2 = 1,0 \text{ (operating temperature } 60 \text{ }^\circ\text{C)}$$

$$C_3 = 17 \cdot \left(c_2 \cdot \frac{C}{P} = 1,0 \cdot \frac{19415}{5000} = 3,88. \right)$$

$$d_g = 22 \text{ mm}$$

$$f = 25 \text{ min}^{-1}$$

$$b = 15^\circ \text{ (half the swiveling angle: } 30^\circ : 2 = 15^\circ\text{)}$$

$$C = 19415 \text{ N}$$

$$P = 5000 \text{ N}$$

$$G_h = 0,25 \cdot 1,0 \cdot 17 \cdot \frac{5}{22 \cdot 15 \cdot 25} \cdot \frac{19415}{5000} \cdot 10^6$$

$$\underline{= 10000 \text{ h} > 8000 \text{ h}}$$

Checking the permissible load of the rod end

$$P_{zul} = C_o \cdot c_2 \cdot c_4$$

$$C_o = 48545 \text{ N}$$

$$c_2 = 1,0 \text{ (operating temperature } 60 \text{ }^\circ\text{)}$$

$$c_4 = 0,2 \text{ (alternating load)}$$

$$P_{zul} = 48545 \cdot 1,0 \cdot 0,2 = \underline{9709 \text{ N} > 5000 \text{ N}}$$

Checking the permissible sliding velocity

$$V_m = 5,82 \cdot 10^{-7} \cdot d_g \cdot \beta \cdot f = 5,82 \cdot 10^{-7} \cdot 22 \cdot 15 \cdot 25$$

$$\underline{= 0,0048 \text{ m/s} < 0,15 \text{ m/s}}$$

Checking the $p \cdot v$ -value

$$p = k \cdot \frac{P}{C} = 50 \cdot \frac{5000}{19415} = 12,87 \text{ N/mm}^2$$

$$p \cdot V_m = 12,87 \cdot 0,0048$$

$$\underline{= 0,061 \text{ N/mm}^2 \cdot \text{m/s} < 0,5 \text{ N/mm}^2 \cdot \text{m/s}}$$



Tolerances

DURBAL-heavy-duty rod ends, series BRM, BRF, BRTM, BRTF, BEM, BEF

d1		Δd_{1mp} tolerance limit		V_{d1p}	V_{d1mp}	Δb_{1s} tolerance limit		$\Delta h_{s,h1s,h2s}$ tolerance limit	
over	incl.	upper	lower	max.	max.	upper	lower	upper	lower
	6	+0,012	0	0,012	0,009	0	- 0,12	+0,8	-1,2
6	10	+0,015	0	0,015	0,011	0	- 0,12	+0,8	-1,2
10	18	+0,018	0	0,018	0,014	0	- 0,12	+1,0	-1,7
18	30	+0,021	0	0,021	0,016	0	- 0,12	+1,4	-2,1
30	50	+0,025	0	0,025	0,019	0	- 0,12	+1,8	-2,7

DURBAL-heavy-duty rod ends, series EM, EF, PM, PF

d1		Δd_{1mp} tolerance limit		V_{d1p}	V_{d1mp}	Δb_{1s} tolerance limit		$\Delta h_{s,h1s,h2s}$ tolerance limit	
over	incl.	upper	lower	max.	max.	upper	lower	upper	lower
	10	+0,002	-0,010	0,008	0,006	0	-0,12	+0,8	-1,2
10	18	+0,003	-0,011	0,008	0,006	0	-0,12	+0,8	-1,2
18	30	+0,003	-0,013	0,010	0,008	0	-0,12	+1,0	-1,7
30	50	+0,003	-0,015	0,012	0,009	0	-0,12	+1,4	-2,1
50	80	+0,004	-0,019	0,015	0,011	0	-0,15	+1,8	-2,7

Dimension and tolerance symbols

- d_1 = nominal bore diameter of the inner ring or joint ball
- Δd_{1mp} = mean bore diameter deviation in one plane, arithmetical mean of the largest and smallest bore diameter
- V_{d1p} = bore diameter variation in one plane, difference between the largest and smallest bore diameter
- V_{d1mp} = mean bore diameter variation, difference between the largest and smallest bore diameter of one inner ring or joint ball
- b_1 = inner ring or joint ball width
- Δb_{1s} = single inner ring or joint ball width deviation
- h, h_1, h_2 = system length from inner ring or ball bore center to shank end
- $\Delta h_s, \Delta h_{1s}, \Delta h_{2s}$ = system length variation of a single rod end

Male thread
greasable,
low maintenance,
shields adapter sizes
according to DIN 648,
series K

Heavy-duty rod ends with integral self-aligning ball bearing

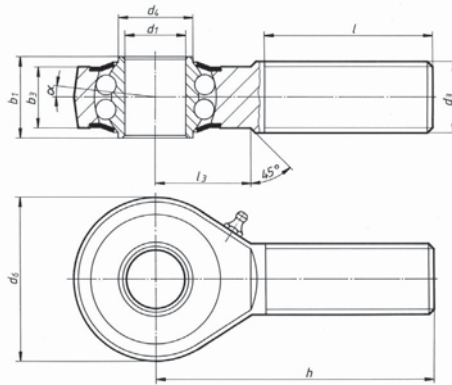

rod end housing:

forged steel, tempered, case hardened, bearing race, ground and lapped, rolled thread, surface galvanized

inner ring:

ball bearing steel, hardened, superfine ground

lubrication: Polyrex EP2 or soap complex
temperature range -20 °C to +120 °C

lubrication nipple:

DIN 3405 D1/A (sizes 6 to 10)
DIN 71412 H1 (sizes 12 to 30)

bearing clearance:

15 - 40 µm radial

tolerances:

see page 10

type	order number right hand thread	order number left hand thread	d ₁	d ₃	d ₄	d ₆	b ₁	b ₃	h
BRM 06	00-501	00-502	6	M 6 X 1.0	9	20	9	6,75	36
BRM 08	00-501	00-502	8	M 8 X 1.25	10,5	24	12	9	42
BRM 10	00-501	00-502	10	M 10 X 1.5	12	28	14	10,5	48
BRM 12	00-501	00-502	12	M 12 X1.75	14,5	32	16	12	54
BRM 14	00-501	00-502	14	M 14X 2.0	17	36	19	13,5	60
BRM 16	00-501	00-502	16	M 16 X2.0	19	42	21	15	66
BRM 18	00-501	00-502	18	M 18 x 1,5	21,5	46	23	16,5	72
BRM 20	00-501	00-502	20	M 20 x 1,5	24,5	50	25	18	78
BRM 22	00-501	00-502	22	M 22 x 1,5	26	54	28	20	84
BRM 25	00-501	00-502	25	M 25 x 2	29,5	64	31	22	94
BRM 30	00-501	00-502	30	M 30 x 2	34,5	70	37	25	110

type	l	l ₃	α [°]	weight [kg]	calculation- factors		speed- limit n _{max} ^[min-1]	basic load rating [N]	
					Y	Y ₀		dyn. C	stat. C ₀
BRM 06	22	12	8,0	0,019	2,09	2,19	1350	2750	650
BRM 08	25	15	8,5	0,036	1,80	1,89	1300	4000	1000
BRM 10	29	15	8,0	0,060	1,90	1,81	1225	4450	1450
BRM 12	33	19	7,5	0,087	1,74	1,82	1125	4950	1800
BRM 14	36	20	6,0	0,135	2,36	2,48	1025	5600	2000
BRM 16	40	22	8,0	0,190	2,24	2,35	975	6250	2350
BRM 18	44	25	8,5	0,270	2,21	2,31	900	7100	2900
BRM 20	47	28	7,0	0,338	2,46	2,58	825	7900	3450
BRM 22	51	26	8,0	0,450	2,35	2,24	725	9300	3980
BRM 25	57	30	5,0	0,602	2,02	2,12	600	11030	5680
BRM 30	66	35	7,5	0,922	2,24	2,35	450	14150	7450

Heavy-duty rod ends with integral self-aligning ball bearing

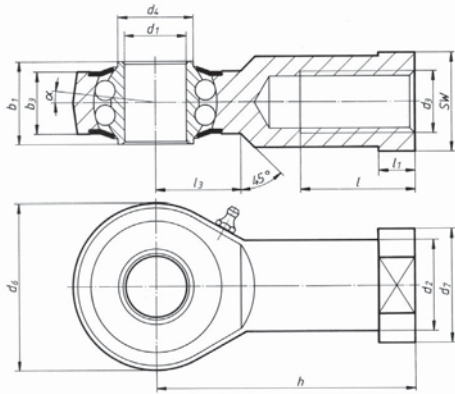

rod end housing:

forged steel, tempered, case hardened bearing race, ground and lapped, surface galvanized

inner ring:

ball bearing steel, hardened, superfine ground

lubrication: Polyrex EP2 or soap complex
temperature range -20 °C to +120 °C

lubrication nipple:

DIN 3405 D1/A (sizes 6 to 10)
DIN 71412 H1 (sizes 12 to 30)

bearing clearance:

15 - 40 µm radial

tolerances:

see page 10

Female thread

Greasable,
low maintenance,
shields adapter sizes
according to DIN 648,
series K



type	order number right hand thread	order number left hand thread.	d ₁	d ₂	d ₃	d ₄	d ₆	d ₇	b ₁	b ₃	h
BRF 06	00-501	00-502	6	10	M 6 X 1.0	9	20	13	9	6,75	30
BRF 08	00-501	00-502	8	12,5	M 8 X 1.25	10,5	24	16	12	9	36
BRF 10	00-501	00-502	10	15	M 10 X 1.5	12	28	19	14	10,5	43
BRF 12	00-501	00-502	12	17,5	M 12 X1.75	14,5	32	22	16	12	50
BRF 14	00-501	00-502	14	20	M 14 X2.0	17	36	25	19	13,5	57
BRF 16	00-501	00-502	16	22	M 16 X2.0	19	42	27	21	15	64
BRF 16SO	01-501	01-502	16	22	M 16 X1.5	19	42	27	21	15	64

BRF 18	00-501	00-502	18	25	M 18 x 1,5	21,5	46	31	23	16,5	71
BRF 20	00-501	00-502	20	27,5	M 20 x 1,5	24,5	50	34	25	18	77
BRF 22	00-501	00-502	22	30	M 22 x 1,5	26	54	38	28	20	84

BRF 25	00-501	00-502	25	30	M 24 x 2	29,5	64	35	31	22	94
BRF 30	00-501	00-502	30	40	M 30 x 2	34,5	70	50	37	25	110

Typ	Nr.	l	l ₁	l ₃	SW	α [°]	weight [kg]	calculation- factors Y	speed- limit n _{max} [min ⁻¹]	basic load rating [N] dyn. C	stat. C ₀
BRF 6	12	5	10	11	8.0	0,024	2,09	2,19	1350	2750	650
BRF 8	16	5	12	14	8.5	0,044	1,80	1,89	1300	4000	1000
BRF 10	20	6,5	15	17	8.0	0,072	1,90	1,81	1225	4450	1450
BRF 12	22	6,5	16	19	7.5	0,107	1,74	1,82	1125	4950	1800
BRF 14	25	8	20	22	6.0	0,160	2,36	2,48	1025	5600	2000
BRF 16	28	8	22	22	8.0	0,224	2,24	2,35	975	6250	2350
BRF 16SO	28	8	22	22	8.0	0,224	2,24	2,35	975	6250	2350
BRF 18	32	10	24	27	8,5	0,293	2,21	2,31	900	7100	2900
BRF 20	33	10	26	30	7,0	0,367	2,46	2,58	825	7900	3450
BRF 22	37	12	26	32	8,0	0,480	2,35	2,24	725	9300	3980
BRF 25	42	10	32	30	5,0	0,572	2,02	2,12	600	11030	5680
BRF 30	51	15	35	41	7,5	0,978	2,24	2,35	450	14150	7450

Male thread
greasable,
low maintenance,
shields

Heavy-duty rod ends with integral self-aligning ball bearing

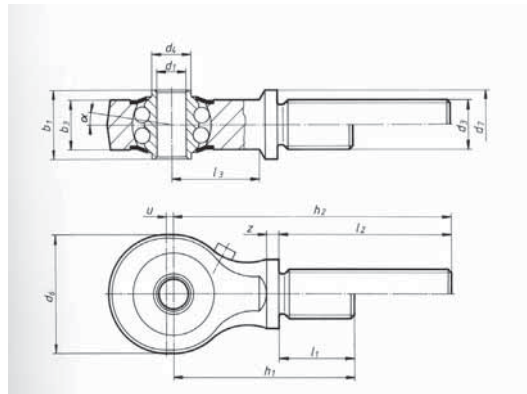

rod end housing:

forged steel, tempered, case hardened bearing race, ground and lapped, rolled thread, surface galvanized

inner ring:

ball bearing steel, hardened, superfine ground

lubrication: Polyrex EP2 or soap complex

temperature range -20 °C to +120 °C

lubrication nipple:

DIN 3405 D1/A

bearing clearance:

15 - 40 µm radial

tolerances:

see page 10

type	order number right hand thread	order number left hand thread.	d ₁	d ₃	d ₄	d ₆	d ₇	b ₁	b ₃
PM 05	00-501	00-502	5	M 8 x 1	7,5	19	12	12	8
PM 05	01-501	01-502	5	M 8 x 1	7,5	19	12	12	8
PM 06	00-501	00-502	6	M 10 x 1	8,5	24	14	14	10
PM 06	02-501	02-502	6	M 10 x 1	8,5	24	14	14	10
PM 08	00-501	00-502	8	M 12 x 1,5	11	30	17	15	10
PM 08	02-501	02-502	8	M 12 x 1,5	11	30	17	15	10
PM 10	00-501	00-502	10	M 14 x 1,5	13,5	36	19	20	14
PM 10	03-501	03-502	10	M 14 x 1,5	13,5	36	19	20	14
PM 12	00-501	00-502	12	M 16 x 1,5	15	40	21	20	14
PM 12	02-501	02-502	12	M 16 x 1,5	15	40	21	20	14
PM 15	00-501	00-502	15	M 20 x 1,5	18,5	42	26	20	14
PM 15	02-501	02-502	15	M 20 x 1,5	18,5	42	26	20	14
PM 17	00-501	00-502	17	M 20 x 1,5	21	48	26	22	16
PM 17	01-501	01-502	17	M 20 x 1,5	21	48	26	22	16
PM 20	00-501	00-502	20	M 24 x 1,5	24	56	30	24	18
PM 20	02-501	02-502	20	M 24 x 1,5	24	56	30	24	18

type	l ₁	l ₂	l ₃	h ₁	h ₂	u	z	α [°]	weight [kg]	calculation- factors Y Y ₀	speed- limit n _{max} [min ⁻¹]	basic load rating [N] dyn. stat. C C ₀
PM 05		39,5	13		57	1,5	2,5	7,0	0,037	1,51 1,58	1350	1610 480
PM 05	16		13	33,5		1,5	2,5	7,0	0,033	1,51 1,58	1350	1610 480
PM 06		42,5	17		64	1,5	2,5	10,5	0,062	1,28 1,34	1300	2445 765
PM 06	19		17	40,5		1,5	2,5	10,5	0,057	1,28 1,34	1300	2445 765
PM 08		46,5	20		72	2	2,5	8,5	0,097	1,9 1,81	1225	2605 985
PM 08	23		20	48,5		2	2,5	8,5	0,088	1,9 1,81	1225	2605 985
PM 10		49,5	28		82	2,5	2,5	9,5	0,168	1,69 1,77	1100	5120 1905
PM 10	26		28	58,5		2,5	2,5	9,5	0,154	1,69 1,77	1100	5120 1905
PM 12		53,5	31		90	3	2,5	7,5	0,226	1,81 1,90	1050	5345 2065
PM 12	29		31	65,5		3	2,5	7,5	0,204	1,81 1,90	1050	5345 2065
PM 15		62,5	30		100	3	2,5	6,5	0,310	2,07 2,17	975	5485 3270
PM 15	36		30	73,5		3	2,5	6,5	0,273	2,07 2,17	975	5485 3270
PM 17		62,5	36		105	3,5	2,5	7,0	0,401	2,35 2,46	875	5575 2680
PM 17	36		36	78,5		3,5	2,5	7,0	0,354	2,35 2,46	875	5575 2680
PM 20		68,5	41		117	3,5	3	5,5	0,587	2,76 2,90	775	6165 3140
PM 20	41		41	89,5		3,5	3	5,5	0,519	2,76 2,90	775	6165 3140

Heavy-duty rod ends with integral self-aligning ball bearing

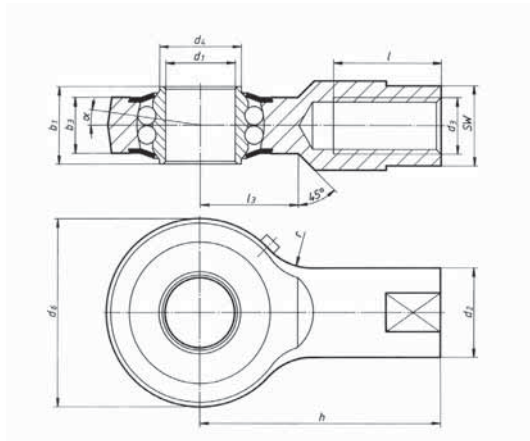

rod end housing:

forged steel, tempered, case hardened bearing race, ground and lapped, surface galvanized

inner ring:

ball bearing steel, hardened, superfine ground

lubrication: Polyrex EP2 or soap-complex
temperature range -20 °C to +120 °C

lubrication nipple:

DIN 3405 D1/A

bearing clearance:

15 - 40 µm radial

tolerances:

see page 10

"Female thread
GREASABLE,
low maintenance,
shields"



type	order number right hand thread	order number left hand thread	d ₁	d ₂	d ₃	d ₄	d ₆	b ₁	b ₃
PF 10	00-501	00-502	10	15	M 8X1.25	13	30	13	9
PF 15	00-501	00-502	15	19	M 12X1.75	17,5	40	16,5	12
PF 20	00-501	00-502	20	22	M 16X2	24	48	20,5	15

type	h	l	l ₃	r	SW	α [°]	weight [kg]	calculation- factors		speed- limit n _{max} ^[min-1]	basic load rating [N]	
								Y	Y ₀		dyn. C	stat. C ₀
PF 10	38	17	14,5	10	13	7,0	0,063	1,90	1,81	1225	2605	985
PF 15	51	24	20	15	17	7,0	0,140	2,30	2,41	1025	5000	1890
PF 20	65	32	22	20	19	6,5	0,223	2,34	2,45	850	6105	2955



DURBAL BRTM

Male thread
GREASABLE,
low maintenance,
shields adapter sizes
according to DIN 648,
series K



Heavy-duty rod ends with integral self-aligning roller bearing

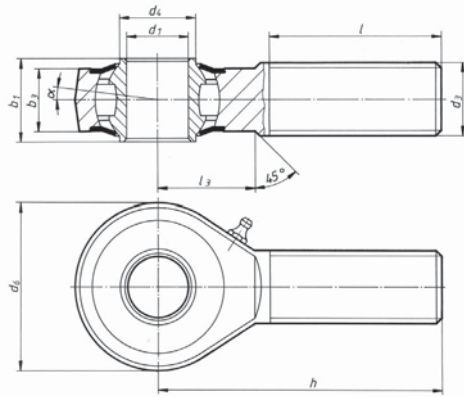

rod end housing:

forged steel, tempered, case hardened bearing race, ground and lapped, rolled thread, surface galvanized

inner ring:

ball bearing steel, hardened, superfine ground

lubrication: Polyrex EP2 or soap-complex
temperature range -20 °C to +120 °C

lubrication nipple:

DIN 71412 HZ

bearing clearance:

15 – 30 µm radial

tolerances:

see page 10

type	order number right hand thread	order number left hand thread	d ₁	d ₃	d ₄	d ₆	b ₁	b ₃
BRTM 12	01-501	01-502	12	M 12 X1.5	14,5	32	16	12
BRTM 16	03-501	03-502	16	M 16 X2.0	19	42	21	15
BRTM 20	00-501	00-502	20	M 20 x 1,5	24,5	50	25	18
BRTM 25	00-501	00-502	25	M 24 x 2	29,5	64	31	22
BRTM 30	00-501	00-502	30	M 30 x 2	34,5	70	37	25

type	h	l	l ₃	α [°]	weight [kg]	speed- limit n _{max} ^[min-1]	basic load rating [N] dyn. C	stat. C ₀
BRTM 12	54	33	19	7,5	0,088	1125	10250	6600
BRTM 16	66	40	22	7,0	0,185	975	13300	8900
BRTM 20	78	47	28	7,0	0,340	825	17000	11700
BRTM 25	94	57	30	5,0	0,596	600	24900	18500
BRTM 30	110	66	35	7,5	0,912	450	32500	24850

Heavy-duty rod ends with integral self-aligning roller bearing

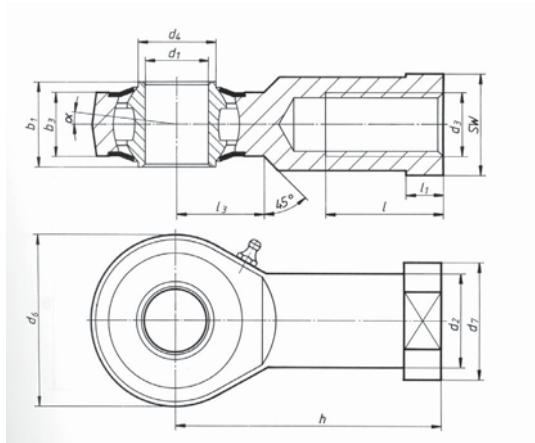

rod end housing:

forged steel, tempered, case hardened bearing race, ground and lapped, surface galvanized

inner ring:

ball bearing steel, hardened, superfine ground

lubrication: Polyrex EP2 or soap-complex
temperature range -20 °C to +120 °C

lubrication nipple:

DIN 71412 H1

bearing clearance:

15 - 30 µm radial

tolerances:

see page 10

Female thread

GREASABLE,

low maintenance,

shields adapter sizes

according to DIN 648,

series K



type	order number		d ₁	d ₂	d ₃	d ₄	d ₆	d ₇	b ₁	b ₃
	right hand thread	left hand thread								
BRTF 12	04-501	04-502	12	17,5	M 12 X 1.5	14,5	32	22	16	12
BRTF 16	03-501	03-502	16	22	M 16 X 2	19	42	27	21	15
BRTF 20	00-501	00-502	20	27,5	M 20 x 1,5	24,5	50	34	25	18
BRTF 25	00-501	00-502	25	30	M 24 x 2	29,5	64	35	31	22
BRTF 30	01-501	01-502	30	40	M 30 x 2	34,5	70	50	37	25

type	h	l	l ₁	l ₃	SW	α [°]	weight [kg]	speed- limit n _{max} ^[min-1]	basic load rating [N]	
									dyn. C	stat. C ₀
BRTF 12	50	22	6,5	16	19	7,5	0,109	1125	10250	6600
BRTF 16	64	28	8	22	22	7,0	0,220	975	13300	8900
BRTF 20	77	33	10	26	30	7,0	0,361	825	17000	11700
BRTF 25	94	42	10	32	30	5,0	0,565	600	24900	18500
BRTF 30	110	51	15	35	41	7,5	1,000	450	32500	24850

Male thread
maintenance free
adapter sizes according
to DIN 648,
series K



Heavy-duty rod ends with integral spherical plain bearing

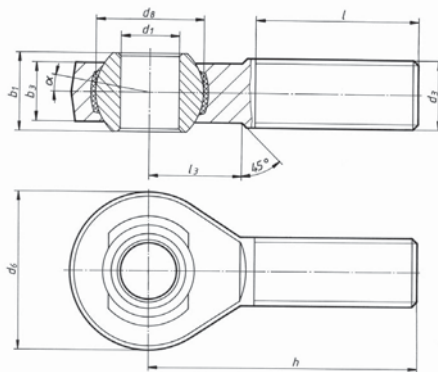

rod end housing:

forged steel, tempered, rolled thread,
surface galvanized

joint ball:

ball bearing steel, hardened and ground,
surface superfinished and chromium plated

race:

Nylon/Teflon/Glass compound

tolerances:

see page 10

type	order number right hand thread	order number left hand thread	d ₁	d ₃	d ₆	d ₈	b ₁	b ₃
BEM 05	20-501	20-502	5	M 5 X 0.8	18	11,06	8	6
BEM 06	20-501	20-502	6	M 6 X 1	20	12,65	9	6,75
BEM 08	20-501	20-502	8	M 8 X 1.25	24	15,82	12	9
BEM 10	20-501	20-502	10	M 10 X 1.5	28	19,00	14	10,5
BEM 12	20-501	20-502	12	M 12 X 1.75	32	22,17	16	12
BEM 14	20-501	20-502	14	M 14 X 2	36	25,35	19	13,5
BEM 16	20-501	20-502	16	M 16 X 2	42	28,52	21	15
BEM 18	20-501	20-502	18	M 18 x 1,5	46	31,70	23	16,5
BEM 20	20-501	20-502	20	M 20 x 1,5	50	34,87	25	18
BEM 22	20-501	20-502	22	M 22 x 1,5	54	38,05	28	20
BEM 25	20-501	20-502	25	M 24 x 2	60	42,80	31	22
BEM 30	20-501	20-502	30	M 30 x 2	70	50,75	37	25

type	h	l	l ₃	α ¹⁾ [°]	α ²⁾ [°]	weight [kg]	basic load rating [N] dyn. C	stat. C ₀
BEM 05	33	20	9	13,0	7,5	0,014	3910	5390
BEM 06	36	22	12	13,0	6,5	0,020	4590	7510
BEM 08	42	25	15	14,5	7,5	0,038	6965	13700
BEM 10	48	29	15	13,5	8,0	0,060	10420	21705
BEM 12	54	33	19	13,0	8,0	0,092	12425	31060
BEM 14	60	36	20	16,0	9,5	0,127	15440	38610
BEM 16	66	40	22	15,5	8,5	0,202	22410	56020
BEM 18	72	44	25	15	9,5	0,250	26325	65810
BEM 20	78	47	28	14,5	9,0	0,327	30805	77010
BEM 22	84	51	26	15,5	10,0	0,440	38230	95580
BEM 25	94	57	30	15,0	10,0	0,630	45350	113380
BEM 30	110	66	35	17,0	10,5	1,015	55010	137520

Heavy-duty rod ends with integral spherical plain bearing

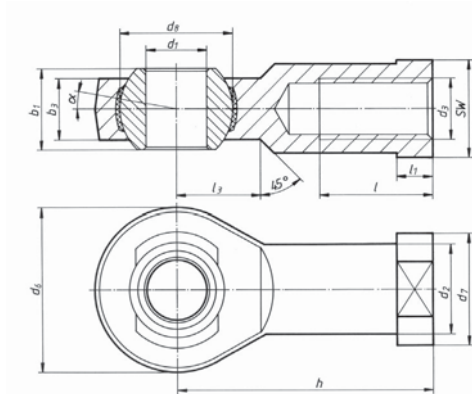

rod end housing:
forged steel, tempered, surface galvanized

joint ball:
ball bearing steel, hardened and ground,
surface superfinished and chromium plated

race:
Nylon/Teflon/Glass compound

tolerances:
see page 10

Female thread
maintenance free
adapter sizes according
to DIN 648,
series K
thread according to
Cetrop RP 103 P



type	order number right hand thread	order number left hand thread	d ₁	d ₂	d ₃	d ₆	d ₇	d ₈	b ₁	b ₃
BEF 05	20-501	20-502	5	9	M 5 X 0.8	18	11	11,06	8	6
BEF 05 SO	22-501	22-502	5	9	M 4 X 0.7	18	11	11,06	8	6
BEF 06	20-501	20-502	6	10	M 6 X 1.0	20	13	12,65	9	6,75
BEF 08	20-501	20-502	8	12,5	M 8 X 1.25	24	16	15,82	12	9
BEF 10	20-501	20-502	10	15	M 10 X 1.5	28	19	19,00	14	10,5
BEF 10 SO	21-501	21-502	10	15	M 10 X 1,25	28	19	19,00	14	10,5
BEF 12	20-501	20-502	12	17,5	M 12 X 1.75	32	22	22,17	16	12
BEF 12 SO	22-501	22-502	12	17,5	M 12 x 1,25	32	22	22,17	16	12
BEF 14	20-501	20-502	14	20	M 14 X 2	36	25	25,35	19	13,5
BEF 16	20-501	20-502	16	22	M 16 X 2	42	27	28,52	21	15
BEF 16 SO	21-501	21-502	16	22	M 16 x 1,5	42	27	28,52	21	15
BEF 18	20-501	20-502	18	25	M 18 x 1,5	46	31	31,70	23	16,5
BEF 20	20-501	20-502	20	27,5	M 20 x 1,5	50	34	34,87	25	18
BEF 22	20-501	20-502	22	30	M 22 x 1,5	54	38	38,05	28	20
BEF 25	20-501	20-502	25	33,5	M 24 x 2	60	42	42,80	31	22
BEF 30	20-501	20-502	30	40	M 30 x 2	70	50	50,75	37	25
BEF 30 SO	22-501	22-502	30	40	M 27 x 2	70	50	50,75	37	25

type	h	l	l ₁	l ₃	SW	α ₁ ¹⁾ [°]	α ₂ ¹⁾ [°]	weight [kg]	basic load rating [N]	
									dyn. C	stat. C ₀
BEF 05	27	10	4	10	9	13,0	7,5	0,018	3910	9775
BEF 05 SO	27	10	4	10	9	13,0	7,5	0,018	3910	9775
BEF 06	30	12	5	10	11	13,0	6,5	0,024	4590	11490
BEF 08	36	16	5	12	14	14,5	7,5	0,045	6965	17420
BEF 10	43	20	6,5	15	17	13,5	8,0	0,074	10420	26050
BEF 10 SO	43	20	6,5	15	17	13,5	8,0	0,074	10420	26050
BEF 12	50	22	6,5	16	19	13,0	8,0	0,109	12425	31060
BEF 12 SO	50	22	6,5	16	19	13,0	8,0	0,109	12425	31060
BEF 14	57	25	8	20	22	16,0	9,5	0,155	15440	38610
BEF 16	64	28	8	22	22	15,5	8,5	0,233	22410	56020
BEF 16 SO	64	28	8	22	22	15,5	8,5	0,233	22410	56020
BEF 18	71	32	10	24	27	15,0	9,5	0,310	26325	65810
BEF 20	77	33	10	26	30	14,5	9,0	0,386	30805	77010
BEF 22	84	37	12	26	32	15,5	10,0	0,520	38230	95580
BEF 25	94	42	12	30	36	15,0	10,0	0,705	45350	113380
BEF 30	110	51	15	35	41	17,0	10,5	1,084	55010	137520
BEF 30 SO	110	51	15	35	41	17,0	10,5	1,084	55010	137520

Male thread
maintenance free
adapter sizes
according to DIN 648,
series E



Heavy-duty rod ends with integral spherical plain bearing

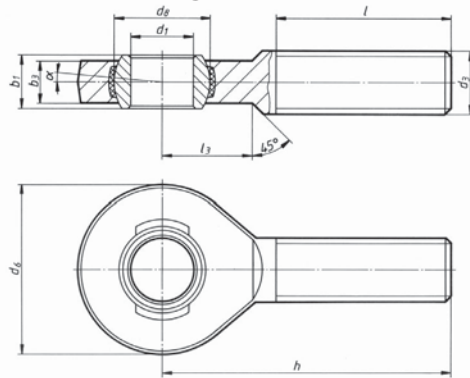

rod end housing:

forged steel, tempered, rolled thread,
surface galvanized

joint ball:

ball bearing steel, hardened and ground,
surface superfinished and chromium plated

race:

Nylon/Teflon/Glass compound

tolerances:

see page 10

type	order number right hand thread	order number left hand thread	d ₁	d ₃	d ₆	d ₈	b ₁	b ₃	h
EM 06	20-501	20-502	6	M 6 X 1	20	10	6	4	36
EM 08	20-501	20-502	8	M 8 X 1.25	23	13	8	5	42
EM 10	20-501	20-502	10	M 10 X 1.5	28	16	9	6	48
EM 12	20-501	20-502	12	M 12 X 1.75	32	18	10	7	54
EM 15	20-501	20-502	15	M 14 X 2	38	22	12	9	63
EM 17	20-501	20-502	17	M 16 X 2	44	25	14	10	69
EM 20	20-501	20-502	20	M 20 x 1,5	51	29	16	12	78
EM 25	20-501	20-502	25	M 24 x 2	62	35,5	20	16	94
EM 30	20-501	20-502	30	M 30 x 2	70	40,7	22	18	110
EM 35	20-501	20-502	35	M 36 x 3	82	47	25	20	140
EM 40	20-501	20-502	40	M 42 x 3	92	53	28	22	145
EM 40 SO	21-501	21-502	40	M 39 x 3	92	53	28	22	150
EM 45	20-501	20-502	45	M 45 x 3	102	60	32	25	165
EM 45 SO	22-501	22-502	45	M 42 x 3	102	60	32	25	163
EM 50	20-501	20-502	50	M 52 x 3	112	66	35	28	195
EM 50 SO	22-501	22-502	50	M 45 x 3	112	66	35	28	185
EM 60	20-501	20-502	60	M 60 x 4	135	80	44	36	225
EM 60 SO	21-501	21-502	60	M 52 x 3	135	80	44	36	210

type	l	l ₃	α ¹⁾ [°]	α ²⁾ [°]	weight [kg]	basic load rating [N]	
						dyn. C	stat. C ₀
EM 06	22	11	13,0	6,5	0,014	2500	6200
EM 08	25	12	15,0	8,0	0,024	4200	10500
EM 10	29	15	12,0	6,0	0,041	6400	16100
EM 12	33	15	10,5	5,0	0,067	9200	22900
EM 15	36	18	8,5	4,5	0,110	13400	33500
EM 17	40	23	10,0	5,5	0,163	19200	48100
EM 20	47	25	9,0	4,5	0,270	25200	63100
EM 25	57	32	7,5	3,5	0,508	42400	106000
EM 30	66	35	6,0	3,0	0,785	54000	135000
EM 35	92	38	6,5	3,5	1,330	70400	176000
EM 40	94	42	7,0	3,5	1,890	86000	215000
EM 40 SO	99	42	7,0	3,5	1,785	86000	215000
EM 45	100	50	7,5	4,0	2,620	107000	268000
EM 45 SO	98	50	7,5	4,0	2,430	107000	268000
EM 50	120	60	6,5	3,0	3,865	132000	330000
EM 50 SO	110	60	6,5	3,0	3,225	132000	330000
EM 60	140	70	6,5	3,5	6,400	208000	520000
EM 60 SO	125	70	6,5	3,5	5,430	208000	520000

Heavy-duty rod ends with integral spherical plain bearing

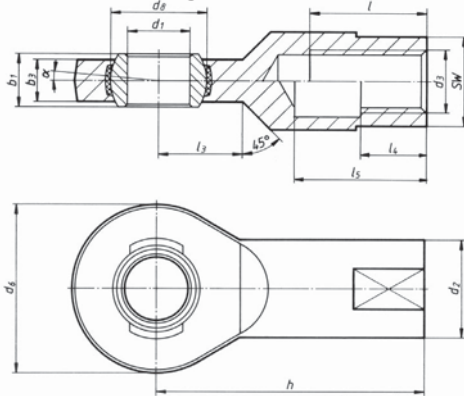

rod end housing:

forged steel, tempered, surface galvanized

joint ball:

ball bearing steel, hardened and ground, surface superfinished and chromium plated

race:

Nylon/Teflon/Glass compound

tolerances:

see page 10

Female thread

maintenance free

adapter sizes

according to DIN 648,

series E



type	order number right hand thread	order number left hand thread	d ₁	d ₂	d ₃	d ₆	d ₈	b ₁	b ₃	h
EF 06	20-501	20-502	6	10	M 6 X 1	20	10	6	4	30
EF 08	20-501	20-502	8	13	M 8 X 1.25	23	13	8	5	36
EF 10	20-501	20-502	10	16	M 10 X 1.5	28	16	9	6	43
EF 10 SO	22-501	22-502	10	16	M 10 x 1,25	28	16	9	6	43
EF 12	20-501	20-502	12	19	M 12 X 1.75	32	18	10	7	50
EF 12 SO	22-501	22-502	12	19	M 12 x 1,25	32	18	10	7	50
EF 15	20-501	20-502	15	22	M 14 X 2	38	22	12	9	61
EF 17	20-501	20-502	17	25	M 16 X 2	44	25	14	10	67
EF 20	20-501	20-502	20	28	M 20 x 1,5	51	29	16	12	77
EF 25	20-501	20-502	25	35	M 24 x 2	62	35,5	20	16	94
EF 30	20-501	20-502	30	42	M 30 x 2	70	40,7	22	18	110
EF 35	20-501	20-502	35	48	M 36 x 3	82	47	25	20	125
EF 35 SO	22-501	22-502	35	48	M 36 x 2	82	47	25	20	130
EF 40	20-501	20-502	40	58	M 42 x 3	92	53	28	22	145
EF 40 SO	22-501	22-502	40	52	M 39 x 3	92	53	28	22	142
EF 45	20-501	20-502	45	65	M 45 x 3	102	60	32	25	165
EF 45 SO	21-501	21-502	45	58	M 42 x 3	102	60	32	25	145
EF 50	20-501	20-502	50	70	M 52 x 3	112	66	35	28	195
EF 50 SO	21-501	21-502	50	62	M 45 x 3	112	66	35	28	160
EF 60	20-501	20-502	60	82	M 60 x 4	135	80	44	36	225
EF 60 SO	21-501	21-502	60	71	M 52 x 3	135	80	44	36	175

type	l	l ₃	l ₄	l ₅	SW	α ¹) [°]	α ²) [°]	weight [kg]	basic load rating [N]	
									dyn. C	stat. C ₀
EF 06	12	11			9	13,0	6,5	0,017	2500	8500
EF 08	16	12			11	15,0	8,0	0,031	4200	10500
EF 10	20	13			14	12,0	6,0	0,054	6400	16100
EF 10 SO	20	13			14	12,0	6,0	0,054	6400	16100
EF 12	22	15			17	10,5	5,0	0,086	9200	22900
EF 12 SO	22	15			17	10,5	5,0	0,086	9200	22900
EF 15	25	18			19	8,5	4,5	0,142	13400	33500
EF 17	28	20			22	10,0	5,5	0,208	19200	48100
EF 20	33	23			24	9,0	4,5	0,290	25200	63100
EF 25	42	30			30	7,5	3,5	0,573	42400	106000
EF 30	51	32			36	6,0	3,0	0,908	54000	135000
EF 35		38	36	61	41	6,5	3,5	1,230	70400	176000
EF 35 SO		38	41	66	41	6,5	3,5	1,230	70400	176000
EF 40		42	42	71	50	7,0	3,5	2,075	86000	215000
EF 40 SO		42	39	66	46	7,0	3,5	1,880	86000	215000
EF 45		50	45	76	55	7,5	4,0	3,085	107000	268000
EF 45 SO		50	42	66	50	7,5	4,0	2,500	107000	268000
EF 50		60	52	89	60	6,5	3,0	3,975	132000	330000
EF 50 SO		60	45	69	55	6,5	3,0	3,200	132000	330000
EF 60		70	60	103	70	6,5	3,5	7,300	208000	520000
EF 60 SO		70	52	71	60	6,5	3,5	5,900	208000	520000



Male thread
greasable,
low maintenance,
shields dimensions
in inches

Heavy-duty rod ends with integral self-aligning ball bearing

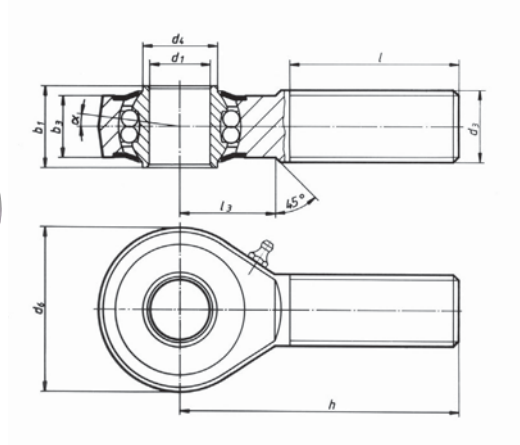

rod end housing:

forged steel, tempered, case hardened bearing race, ground and lapped, rolled thread, surface galvanized

inner ring:

ball bearing steel, hardened, superfine ground

lubrication: Polyrex EP2 or calcium-complex

temperature range -20 °C to +120 °C

lubrication nipple:

DIN 3405 D1/A (sizes 1/4 to 3/8)

DIN 71412 H1 (sizes 1/2 to 1/1)

bearing clearance:

15 - 40 µm radial

tolerances:

see page 10

type	order number right hand thread	left hand thread	d ₁	d ₃ class 2	d ₄	d ₆	b ₁
BRM 3/8	00-501	00-502	.375	.3750-24 UNF	.468	1.000	.551
BRM 1/2	00-501	00-502	.500	.5000-20 UNF	.574	1.311	.624
BRM 5/8	00-501	00-502	.625	.6250-18 UNF	.744	1.654	.826
BRM 3/4	00-501	00-502	.750	.7500-16 UNF	.956	1.750	.984
BRM 1/1	00-501	00-502	1.000	1.0000-12 UNF	1.161	2.362	1.220
BRM 1/1	01-501	01-502	1.000	1.0000-14 UNF	1.161	2.362	1.220

type	b ₃	h	l	l ₃	α [°]	weight [kg]	calculation - factors		speedlimit n _{max} [min ⁻¹]	basic load rating [N]	
							Y	Y ₀		dyn. C	stat. C ₀
BRM 3/8	.413	1.909	1.141	.748	8,0	0,060	1,87	1,83	1225	4360	1425
BRM 1/2	.472	2.460	1.496	.846	7,5	0,109	1,74	1,81	1125	4850	1850
BRM 5/8	.590	2.618	1.574	.944	8,0	0,200	2,24	2,35	975	6250	2350
BRM 3/4	.708	3.090	1.850	1.102	7,0	0,341	2,32	2,43	825	7750	3380
BRM 1/1	.866	3.720	2.244	1.279	5,0	0,590	2,02	2,12	600	11030	5680
BRM 1/1	.866	3.720	2.244	1.279	5,0	0,590	2,02	2,12	600	11030	5680



Heavy-duty rod ends with integral self-aligning ball bearing

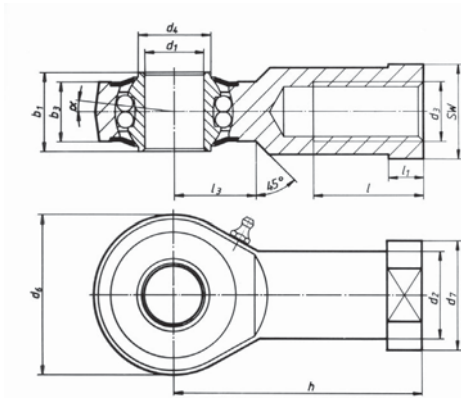

rod end housing:

forged steel, tempered, case hardened bearing race, ground and lapped, surface galvanized

inner ring:

ball bearing steel, hardened, superfine ground

lubrication: Polyrex EP2 or calcium-complex

temperature range -20 °C to +120 °C

lubrication nipple:

DIN 3405 D1/A (sizes 1/4 to 3/8)

DIN 71412 H1 (sizes 1/2 to 1/1)

bearing clearance:

15 - 40 µm radial

tolerances:

see page 10

Female thread
greasable,
low maintenance,
shields dimensions
in inches



type		order number right hand thread	order number left hand thread	d ₁	d ₂	d ₃	d ₄	d ₆	d ₇
BRF	3/8	00-501	00-502	.375	.567	.3750-24 UNF	.468	1.102	.748
BRF	1/2	00-501	00-502	.500	.748	.5000-20 UNF	.574	1.311	.874
BRF	5/8	00-501	00-502	.625	.866	.6250-18 UNF	.744	1.653	1.062
BRF	3/4	00-501	00-502	.750	1.000	.7500-16 UNF	.956	1.750	1.125
BRF	1/1	00-501	00-502	1.000	1.319	1.0000-12 UNF	1.161	2.519	1.377
BRF	1/1	01-501	01-502	1.000	1.319	1.0000-14 UNS	1.161	2.519	1.377

type	b ₁	b ₃	h	l	l ₁	l ₃	SW	α [°]	weight [kg]	calculation- factors		speed- limit n _{max} [min-1]	basic load rating [N]	
										Y	Y ₀		dyn. C	stat. C ₀
BRF 3/8	.551	.413	1.712	.787	.299	.590	.669	8,0	0,072	1,87	1,83	1225	4360	1425
BRF 1/2	.624	.472	2.145	1.102	.279	.649	.757	7,5	0,127	1,74	1,82	1125	4850	1850
BRF 5/8	.826	.590	2.539	1.102	.322	.885	.866	8,0	0,220	2,24	2,35	975	6250	2350
BRF 3/4	.984	.688	3.051	1.299	.409	.854	1.007	7,0	0,2390	2,32	2,43	825	7750	3380
BRF 1/1	1.220	.866	3.720	1.653	.236	1.279	1.181	5,0	0,570	2,02	2,12	600	11030	5680
BRF 1/1	1.220	.866	3.720	1.653	.236	1.279	1.181	5,0	0,570	2,02	2,12	600	11030	5680



DURBAL BRTM

Male thread
greasable,
low maintenance,
shields dimensions
in inches

Heavy-duty rod ends with integral self-aligning roller bearing

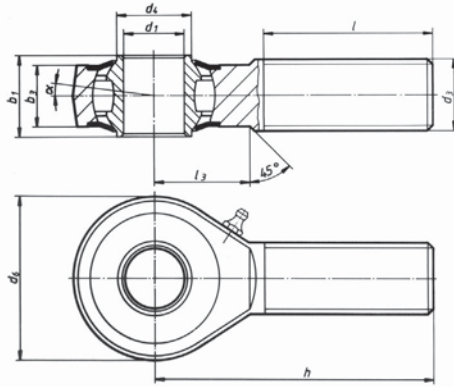

rod end housing:

forged steel, tempered, case hardened bearing race, ground and lapped, rolled thread, surface galvanized

inner ring:

ball bearing steel, hardened, superfine ground

lubrication: polyrex EP2 or calcium-complex

temperature range -20 °C to +120 °C

lubrication nipple:

DIN 71412 H1

bearing clearance:

15 – 30 µm radial

tolerances:

see page 10

type	Nr.	order number		d ₁	d ₃ class 2	d ₄	d ₆	b ₁
		right hand thread	left hand thread					
BRTM	1/2	00-501	00-502	.500	.5000-20 UNF	.574	1.311	.624
BRTM	5/8	00-501	00-502	.625	.6250-18 UNF	.748	1.653	.826
BRTM	3/4	00-501	00-502	.750	.7500-16 UNF	.956	1.968	.984
BRTM	1/1	00-501	00-502	1.000	1.0000-12 UNF	1.161	2.519	1.220
BRTM	1/1	01-501	01-502	1.000	1.0000-14 UNS	1.161	2.519	1.220

type		b ₃	h	l	l ₃	α [°]	weight [kg]	speedlimit n _{max} [min ⁻¹]	basic load rating [N]	
									dyn. C	stat. C ₀
BRTM	1/2	.472	2.460	1.496	.846	7,5	0,109	1125	10250	6600
BRTM	5/8	.590	2.618	1.574	.944	7,0	0,182	975	13300	8900
BRTM	3/4	.708	3.090	1.850	1.102	7,0	0,341	825	16655	11445
BRTM	1/1	.866	3.720	2.244	1.279	5,0	0,590	600	24900	18500
BRTM	1/1	.866	3.720	2.244	1.279	5,0	0,590	600	24900	18500



Heavy-duty rod ends with integral self-aligning roller bearing

rod end housing:

forged steel, tempered, case hardened bearing race, ground and lapped, surface galvanized

inner ring:

ball bearing steel, hardened, superfine ground

lubrication: polyrex EP2 or calcium-complex

temperature range -20 °C to +120 °C

lubrication nipple:

DIN 71412 H1

bearing clearance:

15 – 30 µm radial

tolerances:

see page 10

Female thread

greasable,

low maintenance, drawing dimension

in inches

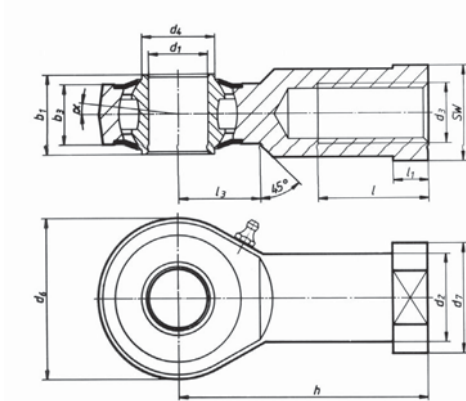

type	order number right hand thread	order number left hand thread	d ₁	d ₂	d ₃ class 2	d ₄	d ₆	d ₇
BRTF 1/2	00-501	00-502	.500	.748	.5000-20 UNF	.574	1.311	.874
BRTF 5/8	00-501	00-502	.625	.866	.6250-18 UNF	.748	1.653	1.063
BRTF 3/4	00-501	00-502	.750	1.082	.7500-16 UNF	.956	1.968	1.338
BRTF 1/1	00-501	00-502	1.000	1.171	1.0000-12 UNF	1.161	2.519	1.377
BRTF 1/1	01-501	01-502	1.000	1.171	1.0000-14 UNS	1.161	2.519	1.377

type	b ₁	b ₃	h	l	l ₁	l ₃	SW	α [°]	weight [kg]	speed- limit n max [min-1]	basic load rating [N] dyn. stat. C C0
BRTF 1/2	.624	.472	2.145	1.102	.251	.649	.757	7,5	0,127	1125	10250 6600
BRTF 5/8	.826	.590	2.539	1.110	.350	.885	.866	7,0	0,218	975	13300 8900
BRTF 3/4	.984	.708	3.051	1.299	.409	1.043	1.181	7,0	0,386	825	16655 11445
BRTF 1/1	1.220	.866	3.720	1.653	.236	1.279	1.181	5,0	0,568	600	24900 18500
BRTF 1/1	1.220	.866	3.720	1.653	.236	1.279	1.181	5,0	0,568	600	24900 18500

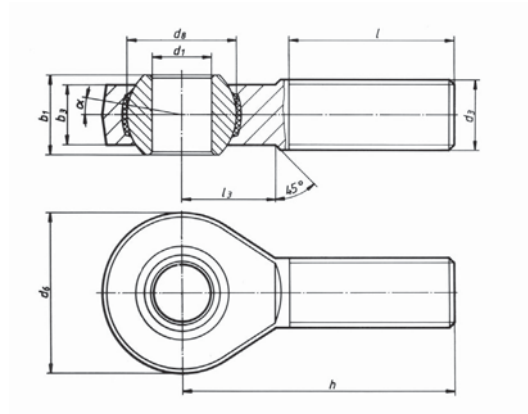

rod end housing:

forged steel, tempered, rolled thread, surface galvanized

joint ball:

ball bearing steel, hardened and ground, surface superfinished and chromium plated

race:

Nylon/Teflon/Glass compound

tolerances:

see page 10

type	order number		d ₁	d ₃	d ₆	d ₈	b ₁
	right hand thread	left hand thread					
BEM 1/4	20-501	20-502	.250	.2500-28 UNF	.750	.516	.374
BEM 3/8	20-501	20-502	.375	.3750-24 UNF	1.000	.719	.499
BEM 1/2	20-501	20-502	.500	.5000-20 UNF	1.311	.876	.624
BEM 1/4	20-501	20-502	.625	.6250-18 UNF	1.654	1.125	.827
BEM 3/8	20-501	20-502	.750	.7500-16 UNF	1.750	1.249	.874
BEM 1/1	20-501	20-502	1.000	1.0000-12 UNF	2.362	1.688	1.220
BEM 1/1	21-501	21-502	1.000	1.0000-14 UNF	2.362	1.688	1.220

Red part numbers are discontinued. Remaining stock only.

type	b ₃	h	l	l ₃	α ¹⁾ [°]	α ²⁾ [°]	weight [kg]	basic load rating [N]	
								dyn. C	stat. C ₀
BEM 1/4	.283	1.594	1.000	.511	17,5	8,0	0,022	3610	9030
BEM 3/8	.405	1.948	1.240	.629	9,5	5,5	0,049	7650	19120
BEM 1/2	.472	2.460	1.500	.846	13,0	9,5	0,109	14649	36624
BEM 5/8	.590	2.618	1.574	.944	15,5	8,5	0,202	22410	56020
BEM 3/4	.688	2.893	1.750	1.023	11,0	7,0	0,249	24870	62175
BEM 1/1	.866	3.720	2.244	1.200	15,5	10,0	0,562	45350	113380
BEM 1/1	.866	3.720	2.244	1.200	15,5	10,0	0,562	45350	113380



Heavy-duty rod ends with integral spherical plain bearing

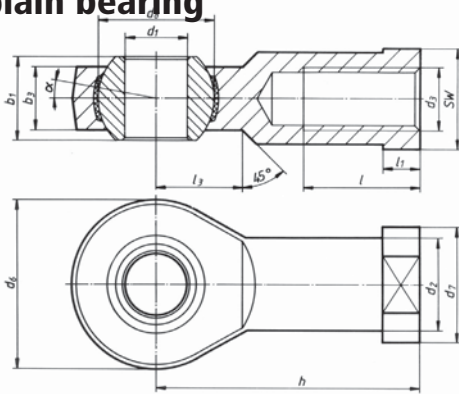

rod end housing:

forged steel, tempered, surface galvanized

joint ball:

ball bearing steel, hardened and ground, surface superfinished and chromium plated

race:

Nylon/Teflon/Glass compound

tolerances:

see page 10

Female thread
maintenance free
dimensions
in inches



type		right hand thread	left hand thread	d ₁	d ₂	d ₃ Class 2	d ₆	d ₇	d ₈
BEF	1/4	20-501	20-502	.250	.374	.2500-28 UNF	.750	.469	.516
BEF	3/8	20-501	20-502	.375	.567	.3750-24 UNF	1.000	.689	.719
BEF	1/2	20-501	20-502	.500	.748	.5000-20 UNF	1.311	.874	.876
BEF	5/8	20-501	20-502	.625	.866	.6250-18 UNF	1.654	1.063	1.125
BEF	3/4	20-501	20-502	.750	1.000	.7500-16 UNF	1.750	1.126	1.249
BEF	1/1	20-501	20-502	1.000	1.319	1.0000-12 UNF	2.362	1.654	1.688
BEF	1/1	21-501	21-502	1.000	1.319	1.0000-14 UNF	2.362	1.654	1.688

Red part numbers are discontinued. Remaining stock only.

type	b1	b3	h	l	l1	l3	SW	α1 ¹⁾ [°]	α2 ¹⁾ [°]	weight [kg]	basic load rating [N]	
											dyn. C	stat. C ₀
BEF 1/4	.374	.283	1.338	.716	.185	.385	.381	17,5	8,0	0,027	4290	10725
BEF 3/8	.499	.405	1.641	.874	.275	.503	.570	9,5	5,5	0,059	7650	19120
BEF 1/2	.624	.472	2.145	1.161	.279	.649	.757	13,0	9,5	0,127	14649	36624
BEF 5/8	.826	.590	2.539	1.102	.350	.885	.866	15,5	8,5	0,231	22410	56020
BEF 3/4	.874	.688	2.905	1.718	.311	.854	1.007	11,0	7,0	0,229	24870	62175
BEF 1/1	1.220	.866	3.720	1.653	.511	1.200	1.417	15,5	10,0	0,663	45350	113380
BEF 1/1	1.220	.866	3.720	1.653	.511	1.200	1.417	15,5	10,0	0,663	45350	113380

Male thread
maintenance free
adapter sizes according
to DIN 648, series K

Heavy-duty rod ends with integral spherical plain bearing in stainless steel

rod end housing:
stainless steel 1.4301, rolled thread

joint ball:
stainless steel 1.4412, hardened and ground,
surface superfinished

race:
Nylon/Teflon/Glass compound

tolerances:
see page 10

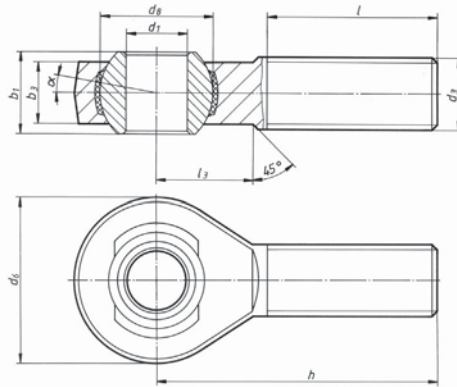

type	order number		d ₁	d ₃	d ₆	d ₈	b ₁	b ₃
	right hand thread	left hand thread						
BEM 05	60-501	60-502	5	M 5 X 0.8	18	11,06	8	6
BEM 06	60-501	60-502	6	M 6 X 1	20	12,65	9	6,75
BEM 08	60-501	60-502	8	M 8 X 1.25	24	15,82	12	9
BEM 10	60-501	60-502	10	M 10 X 1.5	28	19,00	14	10,5
BEM 12	60-501	60-502	12	M 12 X 1.75	32	22,17	16	12
BEM 14	60-501	60-502	14	M 14 X 2	36	25,35	19	13,5
BEM 16	60-501	60-502	16	M 16 X 2	42	28,52	21	15
BEM 18	60-501	60-502	18	M 18 x 1,5	46	31,70	23	16,5
BEM 20	60-501	60-502	20	M 20 x 1,5	50	34,87	25	18
BEM 22	60-501	60-502	22	M 22 x 1,5	54	28,05	28	20
BEM 25	60-501	60-502	25	M 24 x 2	60	42,80	31	22
BEM 30	60-501	60-502	30	M 30 x 2	70	50,75	37	25

type	h	l	l ₃	α ¹⁾ [°]	α ²⁾ [°]	weight [kg]	basic load rating [N]	
							dyn. C	stat. C0
BEM 05	33	20	9	13,0	7,5	0,014	2400	3220
BEM 06	36	22	12	13,0	6,5	0,020	2820	4610
BEM 08	42	25	15	14,5	7,5	0,038	4280	8420
BEM 10	48	29	15	13,5	8,0	0,060	6400	13300
BEM 12	54	33	19	13,0	8,0	0,092	7600	19100
BEM 14	60	36	20	16,0	9,5	0,127	9480	23700
BEM 16	66	40	22	15,5	8,5	0,202	13760	34400
BEM 18	72	44	25	15	9,5	0,250	16160	40400
BEM 20	78	47	28	14,5	9,0	0,327	18960	47400
BEM 22	84	51	26	15,5	10,0	0,440	23480	58700
BEM 25	94	57	30	15,0	10,0	0,630	27860	69650
BEM 30	110	66	35	17,0	10,5	1,015	33800	84500

Heavy-duty rod ends with integral spherical plain bearing in stainless steel

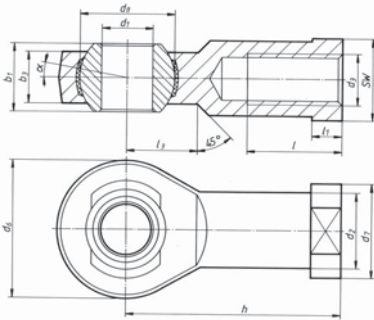

rod end housing:
stainless steel 1.4301

joint ball:
stainless steel 1.4412, hardened and ground,
surface superfinished

race:
Nylon/Teflon/Glass compound

tolerances:
see page 10

Female thread
maintenance free
adapter sizes according
to DIN 648, series K
thread according to
Cetrop RP 103 P



type	order number		d ₁	d ₂	d ₃	d ₆	d ₇	d ₈	b ₁	b ₃
	right hand thread	left hand thread								
BEF 05	60-501	60-502	5	9	M 5 X 0.8	18	11	11,06	8	6
BEF 05 SO	61-501	61-502	5	9	M 4 X 0.7	18	11	11,06	8	6
BEF 06	60-501	60-502	6	10	M 6 X 1	20	13	12,65	9	6,75
BEF 08	60-501	60-502	8	12,5	M 8 X 1.25	24	16	15,82	12	9
BEF 10	60-501	60-502	10	15	M 10 X 1.5	28	19	19,00	14	10,5
BEF 10 SO	61-501	61-502	10	15	M 10 x 1,25	28	19	19,00	14	10,5
BEF 12	60-501	60-502	12	17,5	M 12 X 1.75	32	22	22,17	16	12
BEF 12 SO	61-501	61-502	12	17,5	M 12 x 1,25	32	22	22,17	16	12
BEF 14	60-501	60-502	14	20	M 14 X 2	36	25	25,35	19	13,5
BEF 16	60-501	60-502	16	22	M 16 X 2	42	27	28,52	21	15
BEF 16 SO	61-501	61-502	16	22	M 16 x 1,5	42	27	28,52	21	15
BEF 18	60-501	60-502	18	25	M 18 x 1,5	46	31	31,70	23	16,5
BEF 20	60-501	60-502	20	27,5	M 20 x 1,5	50	34	34,87	25	18
BEF 22	60-501	60-502	22	30	M 22 x 1,5	54	38	38,05	28	20
BEF 25	60-501	60-502	25	33,5	M 24 x 2	60	42	42,80	31	22
BEF 30	60-501	60-502	30	40	M 30 x 2	70	50	50,75	37	25
BEF 30 SO	61-501	61-502	30	40	M 27 x 2	70	50	50,75	37	25

type	h	l	l ₁	l ₃	SW	α ¹⁾ [°]	α ²⁾ [°]	weight [kg]	basic load rating [N]	
									dyn. C	stat. C ₀
BEF 05	27	10	4	10	9	13,0	7,5	0,018	2400	6000
BEF 05 SO	27	10	4	10	9	13,0	7,5	0,018	2400	6000
BEF 06	30	12	5	10	11	13,0	6,5	0,024	2820	7060
BEF 08	36	16	5	12	14	14,5	7,5	0,045	4280	10700
BEF 10	43	20	6,5	15	17	13,5	8,0	0,074	6400	16000
BEF 10 SO	43	20	6,5	15	17	13,5	8,0	0,074	6400	16000
BEF 12	50	22	6,5	16	19	13,0	8,0	0,109	7600	19100
BEF 12 SO	50	22	6,5	16	19	13,0	8,0	0,109	7600	19100
BEF 14	57	25	8	20	22	16,0	9,5	0,155	9480	23700
BEF 16	64	28	8	22	22	15,5	8,5	0,233	13760	34400
BEF 16 SO	64	28	8	22	22	15,5	8,5	0,233	13760	34400
BEF 18	71	32	10	24	27	15,0	9,5	0,310	16160	40400
BEF 20	77	33	10	26	30	14,5	9,0	0,386	18960	47400
BEF 22	84	37	12	26	32	15,5	10,0	0,520	23480	58700
BEF 25	94	42	12	30	36	15,0	10,0	0,705	27860	69650
BEF 30	110	51	15	35	41	17,0	10,5	1,084	33800	84500
BEF 30 SO	110	51	15	35	41	17,0	10,5	1,084	33800	84500

Durbal Dirt Shield

Seal:
neoprene rubber

washer:
stainless steel

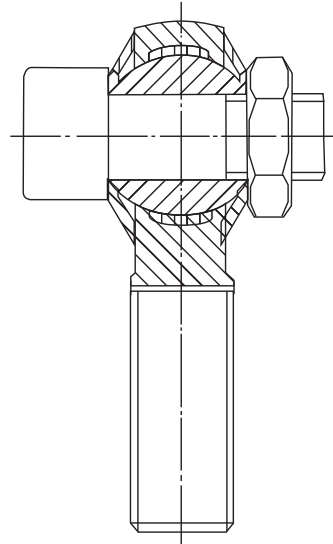
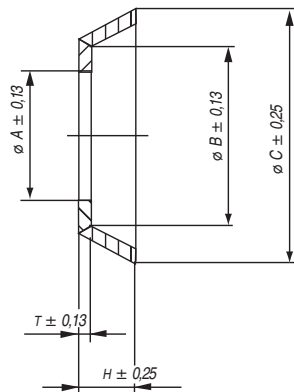

type	order number	A	B	C	H	T
DDS 05	DDS 05	5,25	8,28	11,22	2,41	0,50
DDS 06	DDS 06	6,25	9,53	12,7	3,05	0,69
DDS 08	DDS 08	8,25	12,37	17,78	5,08	1,20
DDS 10	DDS 10	10,25	13,46	20,32	5,59	1,20
DDS 12	DDS 12	12,25	18,54	28,58	6,35	1,20
DDS 14	DDS 14	14,25	20,32	29,21	6,86	1,20
DDS 16	DDS 16	16,25	22,40	31,7	6,80	1,20
DDS 18	DDS 18	18,25	22,60	32,69	8,25	1,20
DDS 20	DDS 20	20,25	25,15	38,10	10,16	1,20
DDS 25	DDS 25	25,25	33,80	53,30	12,70	1,50
DDS 30	DDS 30	30,25	35,56	55,88	13,97	1,53

FRACTIONAL

DDS 1/4	DDS 1/4	0.260	0.375	0.500	0.120	0.027
DDS 3/8	DDS 3/8	0.385	0.530	0.800	0.220	0.047
DDS 1/2	DDS 1/2	0.510	0.730	1.126	0.250	0.047
DDS 5/8	DDS 5/8	0.635	0.882	1.235	0.267	0.047
DDS 3/4	DDS 3/4	0.760	0.1006	1.381	0.367	0.047
DDS 1.0	DDS 1/1	1.010	1.230	2.100	0.500	0.050



DURBAL



DURBAL Inc., 14115 - 63rd Way North
Clearwater, Florida 33760

Tel. 727-531-3040

Fax. 727-539-7824

E-mail: durbal@durbal.com